

## SWITCH 3/2 RAIL 60

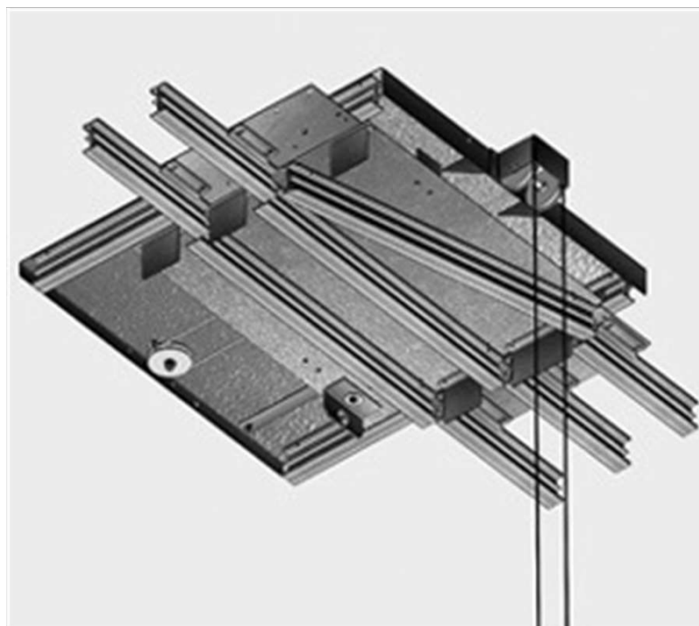

FF FF3766

### Principales caractéristiques

SWITCH 3/2 RAIL 60. (Ref : FF FF3766)

Switch 2/3 rail 60

Switch for double cyclorama Rail Type 60 system. To connect parking rails or feeding rails to the main curtain rail system. Closed loop curtain systems require switches for inserting or removing curtains for maintenance

